



Product Guide

September 2011



THE PUNCHLOCK® ADVANTAGE

Bailey's Professional range of ladders are manufactured using our Punchlock construction technology. Combined with our unique double hollow tread design, this gives the distinct advantages of strength, stiffness and durability unmatched by riveted ladders.



PUNCHLOCK® SUPER STRONG

- 66% stronger than conventional riveted type ladders
- Increased strength and durability



DOUBLE HOLLOW TREAD TWIST RESISTANT

- Increased rigidity and stiffness in the ladder frame
- Reduces ladder twisting



TRI-BRACING SUPER STABLE

- Strongest support between tread and stile
- Eliminates catch points



LIGHTWEIGHT DESIGN SUPER LIGHT

- Industrial strength and safety with a lightweight advantage
- Reduces strain and fatigue

All these distinct advantages are engineered into our Professional range of Aluminium and Fibreglass ladders.

Discover the advantage yourself – invest in our superior Professional range of ladders that will give you years of service.

| | |
|----|--|
| 2 | A Solution for Every Job |
| 3 | Ladder Selection Guide |
| 4 | Step Stools |
| 6 | Single Sided Stepladders |
| 8 | Double Sided Stepladders |
| 11 | Dual Purpose Stepladders |
| 12 | Multipurpose Ladders |
| 13 | Platform Stepladders |
| 16 | Work Platforms |
| 17 | Order Picking Ladders |
| 19 | Extension Ladders |
| 21 | Single Ladders |
| 22 | Trestles |
| 23 | Planks |
| 24 | Mobile Scaffolding |
| 26 | Fibreglass Single and Double Sided Stepladders |
| 27 | Fibreglass Multipurpose Ladders |
| 28 | Fibreglass Platform Stepladders |
| 29 | Fibreglass Extension Ladders |
| 30 | Fibreglass Single Ladders |
| 31 | Load/Duty Rating & Checklist |

Bailey is proud to deliver exciting news about its range of aluminium step and extension ladders. We've upgraded all the old favourites and have a brand new offer of riveted ladders sporting the Bailey brand.

Upgraded Professional Range

With its Punchlock construction, the Bailey range has always offered the optimum mix of strength, durability and light weight. With our new upgraded **Professional Range** offering, we have made some changes to allow us to make the most of this superior construction method. Our **Professional Range** now has a 150kg or 170kg industrial load rating. This is the range aimed at those who use their ladder every day and need a product they can trust, year after year.

New Riveted Trade Range

Our new **Trade Range** is ideal for those who use their ladder a little less frequently. Whether it's a couple of different types and heights for unusual jobs, or for use at home, the **Trade Range** offers great value. The **Trade Range** has an industrial load rating of 150kg.

Household Range

Bailey continues to offer a high quality **Household Range** of ladders, designed for use in and around the home.

Selecting the Right Ladder

| HOUSEHOLD | TRADE | PROFESSIONAL |
|--|---|--|
| Domestic rated | Riveted construction Industrial rated | Punchlock® construction Industrial rated |
| Our range of 100kg and 120kg domestic load rated products. | Our all new range of riveted ladders, with industrial load rating of 150kg. | We have upgraded our popular Punchlock range so they now have load ratings of either 150kg or 170kg. |

Ladder Size

Common height requirements

| Inside | | | | | Outside | | | | |
|---------------|------|------|------|------|-------------|------|------|------|------|
| Cupboards | 1.5m | 1.8m | 2.1m | 2.4m | Walls | 1.5m | 1.8m | 2.1m | 2.4m |
| Light bulbs | 2.1m | 2.4m | 3.0m | - | Windows | 1.8m | 2.1m | 2.4m | 2.7m |
| Wall hangings | 1.5m | 1.8m | 2.1m | 2.4m | Gutters | 2.4m | 3.0m | 6.0m | 6.6m |
| Ceilings | 2.4m | 3.0m | 3.6m | - | Roof access | 3.0m | 6.0m | 9.0m | - |



| Stepladder | | | | | | | | |
|------------------|------|------|------|------|------|------|------|--|
| Height to reach | 1.8m | 2.1m | 2.4m | 2.7m | 3.0m | 3.6m | 4.2m | |
| Size to purchase | 1.2m | 1.5m | 1.8m | 2.1m | 2.4m | 3.0m | 3.6m | |



| Extension Ladder | | | | | | | | | | |
|------------------|------|------|------|------|------|------|------|------|------|-------|
| Height to reach | 2.4m | 3.0m | 3.5m | 4.0m | 4.5m | 5.0m | 6.0m | 7.0m | 8.0m | 9.0m |
| Size to purchase | 3.9m | 4.5m | 5.0m | 5.8m | 6.4m | 6.6m | 7.8m | 9.0m | 9.7m | 10.3m |

Step Stools



PAGE 4

Used in low reach environments, typically for storage retrieval and cupboard access. (Domestic & Industrial)

Single Sided Stepladders



PAGE 6

A general purpose stepladder accessed from one side only. (Industrial)

Double Sided Stepladders



PAGE 8

An 'A' frame stepladder which allows access from either side. (Industrial)

Dual Purpose Stepladders



PAGE 11

Highly versatile – converts from a stepladder to a straight ladder. (Industrial)

Platform Stepladders



PAGE 13

Provides a safe work platform when 'working at heights'. Can be closed for storage. (Industrial)

Step Extension Ladders



PAGE 27

Versatile design which can be used either as a stepladder or extendable straight ladder. (Industrial)

Extendable Stepladders



PAGE 12

Highly versatile – can be used as both a stepladder and a straight ladder with adjustable heights, as well as being separated into two low-level trestles. (Industrial)

Extension Ladders



PAGE 19

Designed for height access for builders, carpenters, plumbers and serious DIY. Height adjustable. (Domestic and Industrial)

Single Ladders

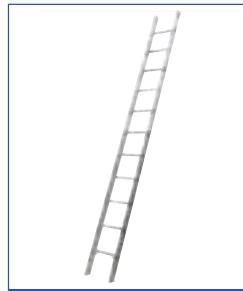

PAGE 21

Designed for height access for builders, carpenters, plumbers and serious DIY. Fixed length. (Industrial)

Fibreglass Ladders



PAGE 26

A versatile range of fibreglass ladders designed for electrical contractors. (Industrial)

Trestles



PAGE 22

'A' frame trestles designed to support planks typically for painting. (Industrial)

Planks



PAGE 23

Work platforms usually used in conjunction with trestles. (Industrial)

Work Platforms



PAGE 16

Foldable work platforms designed for ease of portability. (Industrial)

Order Pickers



PAGE 17

Used for moderate/frequent use stock picking applications. (Industrial)

Mobile Scaffolding



PAGE 24

Safe and secure work platform for working at heights. (Industrial)



Household 100kg Platform Stepladder

HOUSEHOLD DOMESTIC
100KG

- Domestic Duty Rated. Designed for use around the home
- 100kg Load Rating
- Light, strong, aluminium construction
- Wide/deep platform with single handed operation
- European styling and ultra-slim profile for easy storage
- Anti-slip feet for added safety and stability
- Made to Australian and New Zealand Standards AS/NZS 1892.1
- Australian made and owned

| Product No. | Description | Size | Reach Height | EAN Code | Weight |
|-------------|-------------|---------------|--------------|---------------|--------|
| FS10451 | DPS 3 | 504mm (1.7') | 2.5m | 9312097006522 | 2.7kg |
| FS10450 | DPS 4 | 757mm (2.5') | 2.7m | 9312097006515 | 3.25kg |
| FS10449 | DPS 5 | 1009mm (3.3') | 3.0m | 9312097006508 | 3.8kg |
| FS10448 | DPS 6 | 1260mm (4.1') | 3.2m | 9312097006492 | 4.5kg |



StepRight™ 3 with Tool Tray – Steel 100kg Step Stool

HOUSEHOLD DOMESTIC
100KG

- Domestic Duty Rated. Designed for use around the home
- 100kg Load Rating
- Strong, steel construction
- 3 steps for a maximum reach of 2.7m
- Comfortable and convenient hand grip
- Stable, large non-marking anti slip feet
- Secure extra wide slip resistant steps with safety latch
- Easy storage, only 65mm wide when closed
- Handy tool tray for paint tins, measuring tapes, screw drivers, hammers, nuts, bolts and cleaning aids
- Made to Australian and New Zealand Standards AS/NZS 1892.1

| Product No. | Description | Size | Reach Height | EAN Code | Weight |
|-------------|----------------------------|----------------|--------------|---------------|--------|
| FS12888 | StepRight 3 with Tool Tray | 1280mm (50.5") | 2.7m | 9312097047112 | 7kg |



StepRight™ – Steel 100kg Step Stool

HOUSEHOLD / DOMESTIC
100KG

- Domestic Duty Rated. Designed for use around the home
- 100kg Load Rating
- Strong, steel construction
- 2 step and 3 step versions available for a maximum reach height of 2.4m and 2.7m respectively
- Comfortable and convenient hand grip
- Stable, large non-marking anti-slip feet
- Secure extra wide slip resistant steps with safety latch
- Easy storage, only 65mm wide when closed
- Made to Australian and New Zealand Standards AS/NZS 1892.1

| Product No. | Description | Size | Reach Height | EAN Code | Weight |
|-------------|-------------|----------------|--------------|---------------|--------|
| FS12889 | StepRight 2 | 902mm (35.5") | 2.4m | 9312097047129 | 4.5kg |
| FS12887 | StepRight 3 | 1157mm (45.5") | 2.7m | 9312097047105 | 6.1kg |



Handistep™ – Polypropylene 100kg Step Stool

HOUSEHOLD / DOMESTIC
100KG

- Domestic Duty Rated. Designed for use around the home
- 100kg Load Rating
- Tough injection moulded UV stabilised polypropylene construction
- Anti-slip feet and wide base for extra safety and stability
- Unique "lock in" platform
- Slim profile for easy storage
- Made to Australian and New Zealand Standards AS/NZS 1892.3

| Product No. | Description | Size | Reach Height | EAN Code | Weight |
|-------------|-------------|---------------|--------------|---------------|--------|
| FS10408 | Handistep | 620mm (24.4") | 2.4m | 9312097004900 | 3.04kg |



Professional 150kg Single Sided Stepladder

PROFESSIONAL INDUSTRIAL
150KG

- Punchlock® tread design and deep fascia top cap increases the torsional rigidity of the overall ladder frame
- Industrial Duty Rated. Designed for use on industrial work sites where strength, durability and safety is required
- Heavy Duty, 150kg Load Rating
- Strong, heavy duty extruded aluminium construction with additional "Tri-brace" tread bracing
- Incorporating Bailey's patented "Quicklock®" internal arm system which provides extra stability and resistance to ladder-walk
- Anti-slip feet for maximum grip on any surface for added safety and stability
- Made to Australian and New Zealand Standards AS/NZS 1892.1
- Australian made and owned

| Product No. | Description | Size | Reach Height | EAN Code | Weight |
|-------------|--------------------------------|------------|--------------|---------------|---------|
| FS13379 | Pro 150kg Single Sided 4 1.2m | 1.2m (4') | 2.6m | 9312097055131 | 4.4kg |
| FS13380 | Pro 150kg Single Sided 6 1.8m | 1.8m (6') | 3.2m | 9312097055148 | 6.6kg |
| FS13441 | Pro 150kg Single Sided 7 2.1m | 2.1m (7') | 3.5m | 9312097055841 | 7.8kg |
| FS13381 | Pro 150kg Single Sided 8 2.4m | 2.4m (8') | 3.8m | 9312097055155 | 8.9kg |
| FS13382 | Pro 150kg Single Sided 10 3.0m | 3.0m (10') | 4.4m | 9312097055162 | 14.05kg |
| FS13383 | Pro 150kg Single Sided 12 3.6m | 3.6m (12') | 5.0m | 9312097055179 | 19.2kg |

BAILEY Ladderweld



Single Sided Extra Heavy Duty (XHD) - Aluminium 150kg Single Sided Stepladder

PROFESSIONAL INDUSTRIAL
150KG

- All welded construction
- Industrial Duty Rated. Designed for use on industrial work sites where greater strength and safety is required
- 150kg Load Rating
- Extra strong, aluminium construction
- Rectangular hollow stile backleg for greater load bearing strength and stability
- XHD aluminium stiles and treads
- Anti-slip feet for added safety and stability
- Sizes 6-7 step with external arms
- Sizes 10-14 step with internal arms
- Made to Australian and New Zealand Standards AS/NZS 1892.1
- Australian made and owned

| Product No. | Description | Size | Reach Height | EAN Code | Weight |
|-------------|-------------|------------|--------------|---------------|--------|
| FS10661 | SS XHD 6 | 1.8m (6') | 3.2m | 9312097015623 | 7.7kg |
| FS10765 | SS XHD 7 | 2.1m (7') | 3.5m | 9312097021976 | 9.0kg |
| FS10663 | SS XHD 10 | 3.0m (10') | 4.4m | 9312097015647 | 14.9kg |
| FS10664 | SS XHD 12 | 3.6m (12') | 5.0m | 9312097015654 | 17.8kg |
| FS10665 | SS XHD 14 | 4.2m (14') | 5.6m | 9312097015661 | 21.5kg |



Trade 150kg Single Sided Stepladder

TRADE / INDUSTRIAL
150KG

- Riveted construction
- Industrial Duty Rated. Designed for use on industrial work sites where strength, durability and safety is required
- 150kg Load Rating
- Heavy duty extruded aluminium construction with additional “Tri-brace” tread bracing
- Incorporating Bailey’s patented “Quicklock®” internal arm system which provides extra stability and resistance to ladder-walk
- Anti-slip feet for maximum grip on any surface for added safety and stability
- Made to Australian and New Zealand Standards AS/NZS 1892.1

| Product No. | Description | Size | Reach Height | EAN Code | Weight |
|-------------|--------------------------------|-----------|--------------|---------------|--------|
| FS13426 | Trade 150kg Single Side 6 1.8m | 1.8m (6') | 3.2m | 9312097055605 | 7.9kg |
| FS13427 | Trade 150kg Single Side 8 2.4m | 2.4m (8') | 3.8m | 9312097055612 | 10.5kg |



Professional 170kg Double Sided Stepladder

PROFESSIONAL INDUSTRIAL
170KG

- Punchlock® tread design and deep fascia top caps increase torsional rigidity of the overall ladder frames
- Industrial Duty Rated. Designed for use on industrial work sites where greater strength and safety is required
- Extra Heavy Duty, 170kg Load Rating
- Strong, heavy duty extruded aluminium construction with additional “Tri-brace” tread bracing
- Double sided for greater versatility and greater load bearing strength
- The incorporation of interlocking top caps also adds strength and stability
- Internal spreader arms, heavy duty steel – cross braced. Available on models 1.8 to 2.4m
- Anti-slip feet for maximum grip on any surface with reinforcing plates to prevent foot twist for added safety and stability
- Made to Australian and New Zealand Standards AS/NZS 1892.1
- Australian made and owned

| Product No. | Description | Size | Reach Height | EAN Code | Weight |
|-------------|-------------------------------|-----------|--------------|---------------|--------|
| FS13419 | Pro 170kg Double Sided 2 0.6m | 0.6m (2') | 2.0m | 9312097055537 | 3.6kg |
| FS13420 | Pro 170kg Double Sided 3 0.9m | 0.9m (3') | 2.3m | 9312097055544 | 5.3kg |
| FS13421 | Pro 170kg Double Sided 4 1.2m | 1.2m (4') | 2.6m | 9312097055551 | 6.5kg |
| FS13422 | Pro 170kg Double Sided 5 1.5m | 1.5m (5') | 2.9m | 9312097055568 | 9.2kg |
| FS13423 | Pro 170kg Double Sided 6 1.8m | 1.8m (6') | 3.2m | 9312097055575 | 10.9kg |
| FS13424 | Pro 170kg Double Sided 7 2.1m | 2.1m (7') | 3.5m | 9312097055582 | 12.8kg |
| FS13425 | Pro 170kg Double Sided 8 2.4m | 2.4m (8') | 3.8m | 9312097055599 | 14.7kg |



Professional 150kg Big Top Double Sided Stepladder

PROFESSIONAL INDUSTRIAL
150KG

- Punchlock® tread design and deep fascia top caps increase torsional rigidity of the overall ladder frames
- Industrial Duty Rated. Designed for use on industrial work sites
- 150kg Load Rating
- Heavy duty aluminium construction
- Extra wide double sided ladder for greater versatility, safety and greater load bearing strength
- The incorporation of extra wide interlocking top caps also adds strength and stability
- Anti-slip feet for added safety and stability
- Made to Australian and New Zealand Standards AS/NZS 1892.1
- Australian made and owned

| Product No. | Description | Size | Reach Height | EAN Code | Weight |
|-------------|--------------------------|-----------|--------------|---------------|--------|
| FS13393 | Pro 150kg Big Top 3 0.9m | 0.9m (3') | 2.3m | 9312097055278 | 5.25kg |
| FS13394 | Pro 150kg Big Top 4 1.2m | 1.2m (4') | 2.6m | 9312097055285 | 6.4kg |



Professional 150kg Double Sided Stepladder

PROFESSIONAL INDUSTRIAL
150kg

- Punchlock® tread design and deep fascia top caps increase torsional rigidity of the overall ladder frames
- Industrial Duty Rated. Designed for use on industrial work sites where greater strength and safety is required
- Heavy Duty, 150kg Load Rating
- Strong, heavy duty extruded aluminium construction with additional “Tri-brace” tread bracing
- Double sided for greater versatility and greater load bearing strength
- The incorporation of interlocking top caps also adds strength and stability
- Internal spreader arms, heavy duty steel – cross braced. Available on models 1.8 to 3.6m
- Anti-slip feet for maximum grip on any surface for added safety and stability
- Made to Australian and New Zealand Standards AS/NZS 1892.1
- Australian made and owned

| Product No. | Description | Size | Reach Height | EAN Code | Weight |
|-------------|--------------------------------|------------|--------------|---------------|--------|
| FS13384 | Pro 150kg Double Sided 2 0.6m | 0.6m (2') | 2.0m | 9312097055186 | 3.65kg |
| FS13385 | Pro 150kg Double Sided 3 0.9m | 0.9m (3') | 2.3m | 9312097055193 | 4.75kg |
| FS13386 | Pro 150kg Double Sided 4 1.2m | 1.2m (4') | 2.6m | 9312097055209 | 6.1kg |
| FS13387 | Pro 150kg Double Sided 5 1.5m | 1.5m (5') | 2.9m | 9312097055216 | 7.7kg |
| FS13388 | Pro 150kg Double Sided 6 1.8m | 1.8m (6') | 3.2m | 9312097055223 | 9.2kg |
| FS13389 | Pro 150kg Double Sided 8 2.4m | 2.4m (8') | 3.8m | 9312097055230 | 13.3kg |
| FS13390 | Pro 150kg Double Sided 10 3.0m | 3.0m (10') | 4.4m | 9312097055247 | 18.7kg |
| FS13391 | Pro 150kg Double Sided 12 3.6m | 3.6m (12') | 5.0m | 9312097055254 | 24.8kg |
| FS13392 | Pro 150kg Double Sided 16 4.8m | 4.8m (16') | 6.2m | 9312097055261 | 41.2kg |



Double Sided Extra Heavy Duty (XHD) – Aluminium 150kg Double Sided Stepladder

PROFESSIONAL INDUSTRIAL
150kg

- All welded construction
- Industrial Duty Rated. Designed for use on industrial work sites where greater strength and safety is required
- 150kg Load Rating
- Extra strong, aluminium construction
- Double sided for greater versatility and greater load bearing strength
- XHD aluminium stiles and treads
- Anti-slip feet for added safety and stability
- Made to Australian and New Zealand Standards AS/NZS 1892.1
- Australian made and owned

| Product No. | Description | Size | Reach Height | EAN Code | Weight |
|-------------|-------------|------------|--------------|---------------|--------|
| FS10002 | DS XHD 3 | 0.9m (3') | 2.3m | 9312097020016 | 4.2kg |
| FS10003 | DS XHD 4 | 1.2m (4') | 2.6m | 9312097020023 | 5.2kg |
| FS10005 | DS XHD 6 | 1.8m (6') | 3.2m | 9312097020047 | 7.8kg |
| FS10006 | DS XHD 7 | 2.1m (7') | 3.5m | 9312097020054 | 8.8kg |
| FS10007 | DS XHD 8 | 2.4m (8') | 3.8m | 9312097020061 | 10.7kg |
| FS10009 | DS XHD 10 | 3.0m (10') | 4.4m | 9312097020078 | 12.1kg |



Trade 150kg Double Sided Stepladder

TRADE

INDUSTRIAL
150KG

- Riveted construction
- Industrial Duty Rated. Designed for use on industrial work sites where strength, durability and safety is required
- 150kg Load Rating
- Heavy duty extruded aluminium construction with additional "Tri-brace" tread bracing
- Incorporating Bailey's patented "Quicklock®" internal arm system which provides extra stability and resistance to ladder-walk
- Anti-slip feet for maximum grip on any surface for added safety and stability
- Made to Australian and New Zealand Standards AS/NZS 1892.1

| Product No. | Description | Size | Reach Height | EAN Code | Weight |
|-------------|--------------------------------|-----------|--------------|---------------|--------|
| FS13428 | Trade 150kg Double Side 3 0.9m | 0.9m (3') | 2.3m | 9312097055629 | 5.88kg |
| FS13429 | Trade 150kg Double Side 4 1.2m | 1.2m (4') | 2.6m | 9312097055636 | 6.6kg |
| FS13430 | Trade 150kg Double Side 6 1.8m | 1.8m (6') | 3.2m | 9312097055643 | 9.6kg |
| FS13431 | Trade 150kg Double Side 8 2.4m | 2.4m (8') | 3.8m | 9312097055650 | 12.8kg |



Professional 150kg Dual Purpose Stepladder

PROFESSIONAL INDUSTRIAL
150kg

- Punchlock® tread design and deep fascia top caps increase torsional rigidity of the overall ladder frames
- Industrial Duty Rated. Designed for use on industrial work sites
- Heavy Duty 150kg Load Rating
- Strong, aluminium construction
- Easily converts from a stepladder to a single ladder, automatically latches in the straight ladder position by a patented lock and release mechanism
- Converts from a straight ladder back to a stepladder with the press of a button, that saves time on the job
- Tapered back legs provide added stability when used as a stepladder
- Anti-slip feet for added safety and stability
- Made to Australian and New Zealand Standards AS/NZS 1892.1
- Australian made and owned

| Product No. | Description | Size | Reach Height | EAN Code | Weight |
|-------------|-------------------------------|-------------------|--------------|---------------|--------|
| FS13395 | Pro 150kg Dual Purpose 6 1.8m | 1.8/3.2m (6'/10') | 3.2/4.2m | 9312097055292 | 8.7kg |
| FS13396 | Pro 150kg Dual Purpose 7 2.1m | 2.1/3.8m (7'/12') | 3.5/4.8m | 9312097055308 | 10.2kg |
| FS13397 | Pro 150kg Dual Purpose 8 2.4m | 2.4/4.4m (8'/14') | 3.8/5.4m | 9312097055315 | 11.7kg |



Trade 150kg Dual Purpose Stepladder

TRADE INDUSTRIAL
150kg

- Riveted construction
- Industrial Duty Rated. Designed for use on industrial work sites where strength, durability and safety is required
- 150kg Load Rating
- Highly versatile and easily converts from a stepladder to a straight ladder
- Strong and safe single ladder position latched by heavy duty locking hooks and a full step overlapping construction
- Tapered back legs provide added stability when used as a stepladder
- Anti-slip feet for maximum grip on any surface for added safety and stability
- Made to Australian and New Zealand Standards AS/NZS 1892.1

| Product No. | Description | Size | Reach Height | EAN Code | Weight |
|-------------|------------------------------|-------------------|--------------|---------------|--------|
| FS13432 | Trade 150kg Dual Purp 6 1.8m | 1.8/3.2m (6'/10') | 3.2/4.2m | 9312097055667 | 7.2kg |
| FS13433 | Trade 150kg Dual Purp 7 2.1m | 2.1/3.8m (7'/12') | 3.5/4.8m | 9312097055674 | 8.4kg |
| FS13434 | Trade 150kg Dual Purp 8 2.4m | 2.4/4.4m (8'/14') | 3.8/5.4m | 9312097055681 | 9.6kg |



Trade 135kg Extendable Stepladder (BXS)

TRADE

INDUSTRIAL
135KG

- Industrial Duty Rated. Designed for use on industrial work sites
- 135kg Load Rating
- Strong, aluminium construction
- Tool tray can hold a four litre paint can and various tools
- The most versatile ladder you can own
- Double riveted steps for long lasting durability
- Telescopic design quickly adjusts to a comfortable working height
- Adjust height quickly with spring loaded 'J' locks
- Adjust angle positions easily with soft touch push knobs
- Wide flared bottom for firm support and stability
- Anti-slip feet for added safety and stability

| Product No. | Description | Size | Reach Height | EAN Code | Weight |
|-------------|-------------|------------------------|--------------|---------------|--------|
| FS13205 | BXS13 | 1.7m/3.3m (5'6"/10'9") | 2.5/4.3 | 9312097050099 | 13.1kg |
| FS13206 | BXS20 | 2.3m/4.5m (7'6"/14'8") | 3.1/5.5 | 9312097050105 | 16.7kg |





Professional 170kg Platform Stepladder

PROFESSIONAL INDUSTRIAL
170KG

with Safety Gate (Temporary Work Platform)

- Punchlock® tread design increases the torsional rigidity of the overall ladder frame
- Industrial Duty Rated. Designed for use on industrial work sites where strength, durability and safety is required
- Heavy Duty, 170kg Load Rating
- Strong, heavy duty extruded aluminium construction with additional “Tri-brace” tread bracing
- Welded rear frame for strength and durability
- Safety gate improves safety on platform stepladders
- Wide, anti-slip platform (490mm x 400mm) for a secure work area
- Multi function polypropylene handrail/accessories holder
- 900mm handrail height from platform
- Anti-slip rubber feet for maximum grip on any surface
- Made to Australian and New Zealand Standards AS/NZS 1892.1
- Available – optional retractable Castor/Wheel Kits
- Australian made and owned

| Product No. | Description | Platform Height | Reach Height | EAN Code | Weight |
|-------------|--------------------------------|-----------------|--------------|---------------|--------|
| FS13451 | Pro 170kg Platform Gate 3 0.9m | 0.9m (3') | 2.9m | 9312097056022 | 12kg |
| FS13452 | Pro 170kg Platform Gate 4 1.2m | 1.2m (4') | 3.1m | 9312097056039 | 13.3kg |
| FS13453 | Pro 170kg Platform Gate 5 1.5m | 1.5m (5') | 3.4m | 9312097056046 | 14.7kg |
| FS13454 | Pro 170kg Platform Gate 6 1.8m | 1.8m (6') | 3.7m | 9312097056053 | 16.5kg |
| FS13455 | Pro 170kg Platform Gate 7 2.1m | 2.1m (7') | 4.0m | 9312097056060 | 20.8kg |
| FS13456 | Pro 170kg Platform Gate 8 2.4m | 2.4m (8') | 4.3m | 9312097056077 | 22.9kg |



Professional 170kg Platform Stepladder

PROFESSIONAL INDUSTRIAL
170KG

without Safety Gate (Temporary Work Platform)

| Product No. | Description | Platform Height | Reach Height | EAN Code | Weight |
|-------------|---------------------------|-----------------|--------------|---------------|--------|
| FS13398 | Pro 170kg Platform 2 0.6m | 0.6m (2') | 2.6m | 9312097055322 | 8.2kg |
| FS13399 | Pro 170kg Platform 3 0.9m | 0.9m (3') | 2.9m | 9312097055339 | 9.6kg |
| FS13400 | Pro 170kg Platform 4 1.2m | 1.2m (4') | 3.1m | 9312097055346 | 10.9kg |
| FS13401 | Pro 170kg Platform 5 1.5m | 1.5m (5') | 3.4m | 9312097055353 | 12.3kg |
| FS13402 | Pro 170kg Platform 6 1.8m | 1.8m (6') | 3.7m | 9312097055360 | 14.1kg |



Optional Castor/Wheel Kits

| Product No. | Description | EAN Code | Weight |
|-------------|-----------------------|---------------|--------|
| FS22971 | Castor/Wheel Kit 2-6' | 9312097022102 | 2.54kg |
| FS22972 | Castor/Wheel Kit 7-8' | 9312097022119 | 2.54kg |



Heavy Duty (HD) Platform Stepladder (PFS) – Aluminium 150kg

PROFESSIONAL INDUSTRIAL 150KG

Platform Stepladder (Temporary Work Platform)

- Strong, welded aluminium construction
- Industrial Duty Rated. Designed for use on industrial work sites where greater strength and safety is required
- Heavy Duty, 150kg Load Rating
- Fully welded front and rear frames for strength and durability
- Wide, aluminium anti-slip platform (490mm x 400mm) for a secure work area
- 900mm handrail height from platform
- Anti-slip rubber feet for added safety and stability
- Made to Australian and New Zealand Standards AS/NZS 1892.1
- Available – optional retractable Castor/Wheel Kits
- Australian made and owned

| Product No. | Description | Platform Height | Reach Height | EAN Code | Weight |
|-------------|-------------|-----------------|--------------|---------------|---------|
| FS10713 | HD PFS 2 | 572mm (2') | 2.6m | 9312097021150 | 11.15kg |
| FS10714 | HD PFS 3 | 854mm (3') | 2.9m | 9312097021167 | 12.15kg |
| FS10715 | HD PFS 4 | 1136mm (4') | 3.1m | 9312097021174 | 13.45kg |
| FS10716 | HD PFS 5 | 1418mm (5') | 3.4m | 9312097021181 | 14.25kg |
| FS10717 | HD PFS 6 | 1700mm (6') | 3.7m | 9312097021198 | 15.75kg |
| FS10718 | HD PFS 7 | 1982mm (7') | 4.0m | 9312097021204 | 20.05kg |
| FS10719 | HD PFS 8 | 2264mm (8') | 4.3m | 9312097021211 | 21.55kg |



Optional Castor/Wheel Kits

| Product No. | Description | EAN Code | Weight |
|-------------|-----------------------|---------------|--------|
| FS22971 | Castor/Wheel Kit 2-6' | 9312097022102 | 2.54kg |
| FS22972 | Castor/Wheel Kit 7-8' | 9312097022119 | 2.54kg |



Trade 150kg Platform Stepladder (Temporary Work Platform)

TRADE INDUSTRIAL 150KG

- Industrial Duty Rated. Designed for use on industrial work sites
- 150kg Load Rating
- Strong, Henrob™ riveted aluminium construction with additional tread bracing
- Welded rear frame for strength and durability
- Wide, anti-slip platform (490mm x 400mm) for a secure work area
- Multi function polypropylene handrail/accessories holder
- 900mm handrail height from platform
- Anti-slip feet for added safety and stability
- Made to Australian and New Zealand Standards AS/NZS 1892.1
- Available – optional 'fold away' Safety gate
- Australian made and owned

| Product No. | Description | Platform Height | Reach Height | EAN Code | Weight |
|-------------|------------------------|-----------------|--------------|---------------|--------|
| FS13327 | Trade 150kg Platform 3 | 856mm (2.8') | 2.9m | 9312097053793 | 8.7kg |
| FS13328 | Trade 150kg Platform 4 | 1141mm (3.7') | 3.1m | 9312097053809 | 9.8kg |
| FS13329 | Trade 150kg Platform 5 | 1427mm (4.7') | 3.4m | 9312097053816 | 11.3kg |
| FS13330 | Trade 150kg Platform 6 | 1712mm (5.6') | 3.7m | 9312097053823 | 15.5kg |



Safety Gate (for Platform Stepladders)

- Designed to be fitted to Bailey Aluminium and Fibreglass Industrial Platform Stepladders fitted with plastic handrails
- Fully surrounds the user
- Improves safety on platform stepladders
- Maintains a safe working zone
- Folds down for easy access
- Folds away with ladder
- Quick and easy to fit
- Simple to use
- Ladder still fits on roof racks

| Product No. | Description | EAN Code | Weight |
|-------------|-------------|---------------|--------|
| FS13324 | Safety Gate | 9312097053656 | 2.5kg |



Handi-Stand™ – Aluminium 225kg W.L.L. Mobile Work Platform (Temporary Work Platform)

- Designed with the simple “Tilt and Go” wheel system
- 225kg Working Load Limit (W.L.L.)
- Folds up when not in use for easy storage and transportation
- Large stable working platform (1033mm x 480mm)
- Fully welded frame and heavy duty plank section construction for maximum strength and stability
- Designed for industrial and trade applications
- Australian made and owned

| Product No. | Description | Platform Height | Reach Height | EAN Code | Weight |
|-------------|-------------|-----------------|--------------|---------------|--------|
| FS10306 | Handi-Stand | 0.6m (2') | 2.6m | 9312097020580 | 12.6kg |



Xtenda Plank – Aluminium 260kg W.L.L.

- 260kg Working Load Limit (W.L.L.)
- Designed for industrial and trade applications
- Telescopic design quickly adjusts to required working length and height
- Plank extends from 1.2m to 1.96m in 6mm increments
- Adjustable working height from 650mm to 880mm in 6mm increments
- Self latching independent leg adjustment with manual safety lock
- Dual pin locking system on folding legs for increased safety, with single hand release system
- Anti slip boots for added safety and stability

| Product No. | Description | Platform Height | Reach Height | EAN Code | Weight |
|-------------|--------------|-----------------|--------------|---------------|--------|
| FS13352 | Xtenda Plank | 0.65m/0.88m | 2.65m/2.88m | 9312097054493 | 12.5kg |



Work Platform 150kg with Tray

TRADE / INDUSTRIAL
150KG

- Industrial Duty Rated
- Designed for use on industrial work sites
- 150kg Load Rating
- Light, strong, aluminium construction
- Compact and easily portable
- Provides a 1 metre work zone
- Platform height is 0.51m
- Tool Tray provides handy storage of paint cans, drills and other tools
- Tool Tray fits up to 4 litre paint can

| Product No. | Description | Platform Height | Reach Height | EAN Code | Weight |
|-------------|----------------------|-----------------|--------------|---------------|--------|
| FS13266 | Work Platform w/tray | 0.51m (1'8") | 2.5m | 9312097051676 | 7.2kg |



Supplied in flat pack assembly with detailed assembly instructions.

Deluxe Order Picker (DOP) with Safety Gate – Aluminium 150kg

PROFESSIONAL INDUSTRIAL
150KG

Order Picking Ladder – Non-Folding Work Platform (Temporary Work Platform)

- Industrial Duty Rated. Designed for use on commercial sites and warehouses
- 150kg Load Rating
- Extra strong, aluminium construction with XHD stiles and 100mm wide treads for superior durability
- Fully welded construction
- Patented automatic retracting wheel system fitted with heavy duty swivel castors
- Ideal for high frequency stock picking applications
- Easy to move and use
- 900mm high square handrail on three sides to meet work cover requirements
- Safety gate fitted as standard
- 590mm x 710mm platform for ladders up to 2.4m high
- 590mm x 910mm platform for ladders over 2.4m high
- Made to Australian and New Zealand Standards AS/NZS 1892.1
- Australian made and owned

| Product No. | Description | Platform Height | Reach Height | EAN Code | Weight |
|-------------|-------------------------------|-----------------|--------------|---------------|--------|
| FS10880 | DOP 3 w/ Safety Gate | 0.9m (3') | 2.8m | 9312097025325 | 28.0kg |
| FS10881 | DOP 4 w/ Safety Gate | 1.2m (4') | 3.1m | 9312097025332 | 29.5kg |
| FS10882 | DOP 5 w/ Safety Gate | 1.5m (5') | 3.4m | 9312097025349 | 32.5kg |
| FS10883 | DOP 6 w/ Safety Gate | 1.8m (6') | 3.7m | 9312097025356 | 34.0kg |
| FS10884 | DOP 7 w/ Safety Gate | 2.1m (7') | 3.9m | 9312097025363 | 38.0kg |
| FS10885 | DOP 8 w/ Safety Gate | 2.4m (8') | 4.2m | 9312097025370 | 40.5kg |
| FS10886 | DOP 10 w/ Safety Gate | 3.0m (10') | 4.8m | 9312097025387 | 55.5kg |
| FS10887 | DOP 12 w/ Safety Gate | 3.6m (12') | 5.3m | 9312097025394 | 61.5kg |
| FS10888 | DOP 14 w/ Safety Gate | 4.2m (14') | 5.9m | 9312097025400 | 69.0kg |
| FS23025 | Shelf & Safety Gate Kit 3-8 | - | - | 9312097026407 | 3.5kg |
| FS23026 | Shelf & Safety Gate Kit 10-14 | - | - | 9312097026414 | 4.8kg |



Supplied in flat pack assembly with detailed assembly instructions.
Safety gate shown is optional extra.

Order Picker (OP) MKII – Aluminium 130kg

PROFESSIONAL INDUSTRIAL
130KG

Order Picking Ladder – Non-Folding Work Platform (Temporary Work Platform)

- Industrial Duty Rated. Designed for use on commercial sites and warehouses
- 130kg Load Rating
- Light, strong, aluminium construction with heavy duty stiles and tread
- Fully welded construction
- Box section back legs gives greater strength and rigidity when working at heights
- Ideal for moderate stock picking applications
- Highly manoeuvrable and easy to use
- Spring loaded castors
- 100mm high kick plate on three sides
- 900mm high square handrail design for greater comfort and grip when climbing and added safety
- Optional extra safety gate (fits in 5 minutes)
- Made to Australian and New Zealand Standards AS/NZS 1892.1
- Australian made and owned

| Product No. | Description | Platform Height | Reach Height | EAN Code | Weight |
|-------------|-------------|-----------------|--------------|---------------|--------|
| FS10863 | OP 3 MKII | 0.9m (3') | 2.8m | 9312097024939 | 17.5kg |
| FS10864 | OP 4 MKII | 1.2m (4') | 3.1m | 9312097024946 | 19.5kg |
| FS10865 | OP 5 MKII | 1.5m (5') | 3.4m | 9312097024953 | 22.5kg |
| FS10866 | OP 6 MKII | 1.8m (6') | 3.7m | 9312097024960 | 23.5kg |
| FS10867 | OP 7 MKII | 2.1m (7') | 3.9m | 9312097024977 | 28.5kg |
| FS10868 | OP 8 MKII | 2.4m (8') | 4.2m | 9312097024984 | 30.5kg |
| FS10869 | OP 10 MKII | 3.0m (10') | 4.8m | 9312097024991 | 34.5kg |
| FS10870 | OP 12 MKII | 3.6m (12') | 5.3m | 9312097025004 | 41.0kg |
| FS22995 | Safety Gate | - | - | 9312097025196 | 2.8kg |



Supplied in flat pack assembly with detailed assembly instructions.

Riveted Order Picker (ROP) – Aluminium 130kg

Order Picking Ladder – Non-Folding Work Platform (Temporary Work Platform)

TRADE

INDUSTRIAL
130kg

- Industrial Duty Rated. Designed for use on commercial sites and warehouses
- 130kg Load Rating
- Strong, aluminium construction with heavy duty stiles and treads Henrob™ riveted front frame
- Box section back legs gives greater strength and rigidity when working at heights
- Ideal for moderate stock picking applications
- Highly maneuverable and easy to use
- Spring loaded castors
- Anti-slip feet for added safety and stability
- 900mm high square handrail design for greater comfort and grip when climbing and added safety
- Optional extra safety gate (fits in 5 minutes)
- Made to Australian and New Zealand Standards AS/NZS 1892.1
- Australian made and owned



Safety gate shown is optional extra.

| Product No. | Description | Platform Height | Reach Height | EAN Code | Weight |
|-------------|-------------|-----------------|--------------|---------------|--------|
| FS13166 | ROP 3 | 0.9m (3') | 2.8m | 9312097049536 | 17.5kg |
| FS13167 | ROP 4 | 1.2m (4') | 3.1m | 9312097049543 | 19.5kg |
| FS13168 | ROP 5 | 1.5m (5') | 3.4m | 9312097049550 | 22.5kg |
| FS13169 | ROP 6 | 1.8m (6') | 3.7m | 9312097049567 | 23.5kg |
| FS13170 | ROP 7 | 2.1m (7') | 3.9m | 9312097049574 | 28.5kg |
| FS13171 | ROP 8 | 2.4m (8') | 4.2m | 9312097049581 | 30.5kg |
| FS22995 | Safety Gate | - | - | 9312097025196 | 2.8kg |



Professional 150kg Extension Ladder

PROFESSIONAL INDUSTRIAL
150KG

- Punchlock® flat tread 'D' shaped rungs for secure footing
- Industrial Duty Rated. Designed for use on industrial work sites where greater strength and safety is required
- 150kg Load Rating
- XHD strong, aluminium construction
- Interlocking stiles and swaged rung to stile joint for maximum resistance to twist and side sway
- Sturdy, corrosion resistant aluminium
- Patented convenient side pulley and rope extension system to keep rope away from the users' feet
- Anti-slip feet for added safety and stability
- Bailey Level-Eze® Ladder Leveller and accessories available
- Made to Australian and New Zealand Standards AS/NZS 1892.1
- Australian made and owned

*Pro 150kg 8 and 9 models do not feature rope and pulley system

| Product No. | Description | Size | Reach Height | EAN Code | Weight |
|-------------|-----------------------------|-----------------|--------------|---------------|--------|
| FS13407 | Pro 150kg Extension 8 2.4m* | 2.4/4.0m (8') | 5.0m | 9312097055414 | 10.2kg |
| FS13408 | Pro 150kg Extension 9 2.7m* | 2.7/4.6m (9') | 5.6m | 9312097055421 | 11.3kg |
| FS13409 | Pro 150kg Extension 10 3.0m | 3.0/5.2m (10') | 6.2m | 9312097055438 | 12.8kg |
| FS13410 | Pro 150kg Extension 11 3.3m | 3.3/5.8m (11') | 6.8m | 9312097055445 | 14.0kg |
| FS13411 | Pro 150kg Extension 12 3.6m | 3.6/6.4m (12') | 7.4m | 9312097055452 | 15.1kg |
| FS13412 | Pro 150kg Extension 13 4.2m | 4.2/7.3m (13') | 8.3m | 9312097055469 | 21.1kg |
| FS13413 | Pro 150kg Extension 14 4.5m | 4.5/7.9m (14') | 8.9m | 9312097055476 | 27.0kg |
| FS13414 | Pro 150kg Extension 15 4.8m | 4.8/8.5m (15') | 9.5m | 9312097055483 | 28.7kg |
| FS13415 | Pro 150kg Extension 16 5.1m | 5.1/9.1m (16') | 10.1m | 9312097055490 | 30.9kg |
| FS13416 | Pro 150kg Extension 17 5.4m | 5.4/9.7m (17') | 10.7m | 9312097055506 | 32.4kg |
| FS13417 | Pro 150kg Extension 18 6.0m | 6.0/10.6m (18') | 11.6m | 9312097055513 | 36.3kg |
| FS13418 | Pro 150kg Extension 20 6.3m | 6.3/11.2m (20') | 12.2m | 9312097055520 | 37.8kg |



Professional 130kg Extension Ladder with Leveller

PROFESSIONAL INDUSTRIAL
130KG

- Punchlock® flat 'D' shaped rungs for secure footing
- Industrial Duty Rated. Designed for use on industrial work sites
- 130kg Load Rating
- Strong, aluminium construction
- Factory fitted automatic ladder levelling system allows for safe use on uneven surfaces
- Interlocking stiles and swaged rung to stile joint for maximum resistance to twist and side sway
- Sturdy, corrosion resistant aluminium
- Patented convenient side pulley rope extension system to keep rope away from the users' feet
- Anti-slip feet for added safety and stability
- Made to Australian and New Zealand Standards AS/NZS 1892.1
- Australian made and owned

| Product No. | Description | Size | Reach Height | EAN Code | Weight |
|-------------|--------------------------------|----------------|--------------|---------------|--------|
| FS13462 | Pro 130kg Ext Leveller 10 3.2m | 3.2/5.0m (10') | 6m | 9312097056145 | 14.8kg |
| FS13463 | Pro 130kg Ext Leveller 12 3.8m | 3.8/6.2m (12') | 7.2m | 9312097056152 | 17.1kg |



Household 100kg Extension Ladder

HOUSEHOLD / DOMESTIC
100KG

- Domestic Duty Rated. Designed for use around the home
- 100kg Load Rating
- Light yet durable aluminium construction
- Anti-slip feet for extra safety and stability
- Serrated 'O' rungs for secure footing
- Manual extension (no rope and pulley)
- Slim profile for easy storage
- Convenient access around the home
- Made to Australian and New Zealand Standards AS/NZS 1892.1
- Australian made and owned

| Product No. | Description | Size | Reach Height | EAN Code | Weight |
|-------------|-------------|-------------------|--------------|---------------|--------|
| FS20016 | Dom Ext 8 | 2.4/3.9m (8'/13') | 3.4/4.9m | 9312097005006 | 7.1kg |
| FS20017 | Dom Ext 9 | 2.7/4.5m (9'/15') | 3.7/5.5m | 9312097005013 | 8.1kg |

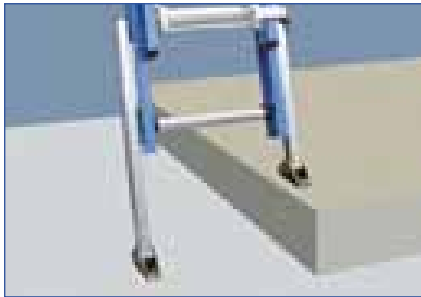

Level-Eze™ Ladder Leveller

- Heavy Duty constructions suits aluminium and fibreglass ladders
- Ideal for stairs and uneven surfaces
- Adjusts up to 228mm (nominal)
- Professional, BMKD, FSXN, FXN, BMKS, GALAXY and FSS Bailey Ladders tested for conformance to AS/NZS 1892
- FSXN and GALAXY models require an adaptor plate
- Factory fit options available on new ladders

| Product No. | Description | EAN Code | Weight |
|-------------|----------------------------------|---------------|--------|
| FS22943 | Bailey Level-Eze Ladder Leveller | 9312097018679 | 4.0kg |
| FS22963 | Professional 150kg Adaptor Kit | 9312097020818 | 0.2kg |
| FS22944 | Fibreglass 130kg Adaptor Kit | 9312097018686 | 1.2kg |



Professional 150kg Single Ladder

PROFESSIONAL INDUSTRIAL
150KG

- Punchlock® flat 'D' shaped rungs for surer footing and strength
- Industrial Duty Rated. Designed for use on industrial work sites where greater strength and safety is required
- 150kg Load Rating
- Extra strong, corrosion resistant aluminium construction
- XHD aluminium stiles and treads
- Anti-slip rubber feet, with reinforcing plates for added safety and stability
- Made to Australian and New Zealand Standards AS/NZS 1892.1
- Level-Eze® Ladder Leveller and accessories available
- Australian made and owned

| Product No. | Description | Size | Reach Height | EAN Code | Weight |
|-------------|-------------|-------------|--------------|---------------|--------|
| FS20283 | BMKS 8 | 2.44m (8') | 3.44m | 9312097018099 | 5.5kg |
| FS20284 | BMKS 10 | 3.05m (10') | 4.05m | 9312097018105 | 7.0kg |
| FS20285 | BMKS 12 | 3.66m (12') | 4.66m | 9312097018112 | 8.3kg |
| FS20286 | BMKS 14 | 4.27m (14') | 5.27m | 9312097018129 | 10.9kg |
| FS20287 | BMKS 16 | 4.88m (16') | 5.88m | 9312097018136 | 12.6kg |
| FS20288 | BMKS 18 | 5.49m (18') | 6.49m | 9312097018143 | 14.0kg |
| FS20289 | BMKS 20 | 6.10m (20') | 7.10m | 9312097018150 | 15.6kg |



Aluminium Trestle 120kg with levellers

PROFESSIONAL INDUSTRIAL
120KG

- Industrial Duty Rated
- 120kg Load Rating
- Light, strong, welded aluminium construction
- Five sizes available to cover a variety of applications
- Leveller system – 200mm total adjustment
- 12mm (1/2") adjustment increments
- Rung to stile joints are fully welded
- Large sole plates with stake holes
- Internal Spreader arms – unique Bailey design
- XHD stile and rung construction
- Made to Australian and New Zealand Standards AS/NZS 1892.1
- Australian made and owned

| Product No. | Description | Size | Reach Height | EAN Code | Weight |
|-------------|-------------------------------------|---------------|--------------|---------------|--------|
| FS12957 | Aluminium Trestle 1.8m w/ Levellers | 1.75m (5'9") | 2.8m | 9312097048232 | 14.2kg |
| FS12958 | Aluminium Trestle 2.4m w/ Levellers | 2.33m (7'8") | 3.4m | 9312097048249 | 17.2kg |
| FS12959 | Aluminium Trestle 3.0m w/ Levellers | 2.92m (9'7") | 4.0m | 9312097048256 | 21.2kg |
| FS12960 | Aluminium Trestle 3.6m w/ Levellers | 3.50m (11'6") | 4.6m | 9312097048263 | 25.2kg |
| FS12961 | Aluminium Trestle 4.2m w/ Levellers | 4.08m (13'5") | 5.2m | 9312097048270 | 29.2kg |



Aluminium Trestle 120kg

PROFESSIONAL INDUSTRIAL
120KG

- Industrial Duty Rated
- 120kg Load Rating
- Light, strong, welded aluminium construction
- Rung to stile joints are fully welded
- Large sole plates with stake holes
- Internal spreader arms – unique Bailey design
- XHD stile and rung construction
- Made to Australian and New Zealand Standards AS/NZS 1892.1
- Australian made and owned

| Product No. | Description | Size | Reach Height | EAN Code | Weight |
|-------------|------------------------|---------------|--------------|---------------|--------|
| FS10409 | Aluminium Trestle 1.2m | 1.15m (3'9") | 2.2m | 9312097005099 | 9.4kg |
| FS10410 | Aluminium Trestle 1.8m | 1.75m (5'9") | 2.8m | 9312097005105 | 13.0kg |
| FS10411 | Aluminium Trestle 2.4m | 2.33m (7'8") | 3.4m | 9312097005112 | 16.5kg |
| FS10412 | Aluminium Trestle 3.0m | 2.92m (9'7") | 4.0m | 9312097005129 | 21.0kg |
| FS10413 | Aluminium Trestle 3.6m | 3.50m (11'6") | 4.6m | 9312097005136 | 24.3kg |
| FS10414 | Aluminium Trestle 4.2m | 4.08m (13'5") | 5.2m | 9312097005143 | 28.4kg |
| FS10415 | Aluminium Trestle 4.8m | 4.67m (15'4") | 5.8m | 9312097005150 | 32.5kg |



Deluxe Aluminium Plank – 225kg per 2.4m W.L.L.

- Designed for use on industrial work sites or around the home
- 225kg Working Load Limit (W.L.L.) per 2.4m span
- Strong, triple hollow extruded aluminium construction
- Raised corrugated aluminium strips for sound footing
- Anti-slip rubber strips
- High grade T6 cast alloy end caps
- Cross sectional dimensions 225mm wide x 50mm deep
- Made to Australian Standards AS 1577

| Product No. | Description | Size | EAN Code | Weight |
|-------------|---------------------------|------------|---------------|--------|
| FS12589 | Deluxe Aluminium Plank 3m | 3m (9'8") | 9312097043442 | 10.6kg |
| FS12590 | Deluxe Aluminium Plank 4m | 4m (13'2") | 9312097043459 | 13.5kg |
| FS12591 | Deluxe Aluminium Plank 5m | 5m (16'4") | 9312097043466 | 16.5kg |
| FS12592 | Deluxe Aluminium Plank 6m | 6m (19'7") | 9312097043473 | 20.0kg |



Economy Aluminium Plank – 225kg per 2.4m W.L.L.

- Designed for use on industrial work sites or around the home
- 225kg Working Load Limit (W.L.L.) per 2.4m span
- Lightweight, yet durable corrosion resistant aluminium construction
- Non-slip knurled surface for sound footing
- High grade T6 cast alloy end caps
- Cross sectional dimensions 225mm wide x 50mm deep
- Made to Australian Standards AS 1577

| Product No. | Description | Size | EAN Code | Weight |
|-------------|----------------------------|------------|---------------|--------|
| FS12593 | Economy Aluminium Plank 3m | 3m (9'8") | 9312097043480 | 9.8kg |
| FS12594 | Economy Aluminium Plank 4m | 4m (13'2") | 9312097043497 | 13.0kg |
| FS12595 | Economy Aluminium Plank 5m | 5m (16'4") | 9312097043503 | 16.2kg |
| FS12596 | Economy Aluminium Plank 6m | 6m (19'7") | 9312097043510 | 19.4kg |



Mini Rise™ – Aluminium 225kg W.L.L. (2 person)

Mobile Scaffolding

- Tested and Passes AS/NZS 1576.1 & .3
- 225kg Working Load Limit (W.L.L.) (2 person)
- Registered design by Victorian Work Cover REG # V0320131 (Reciprocal rights in all other states)
- Wide and stable working platform (1800mm x 700mm) up to a maximum platform height of 3.7m
- Integrated trapdoor to allow safe internal access to the work platform
- Optional adjustable castors available for use on uneven or sloping surfaces
- Non-slip platform surface
- Complete with full work instruction
- Fully welded construction
- Lightweight frame and braces constructed using super tough T6 Aluminium
- Super quick set up time (2 minutes, Base Pack)
- Compact design to allow for easy storage and transport (overall dimensions when folded L=1900 x W=940 x D=300)
- Lockable swivel castors for easy and quick relocation
- Designed to fit through narrow internal/external work spaces
- Australian made and owned

Mini Rise grows with your requirements

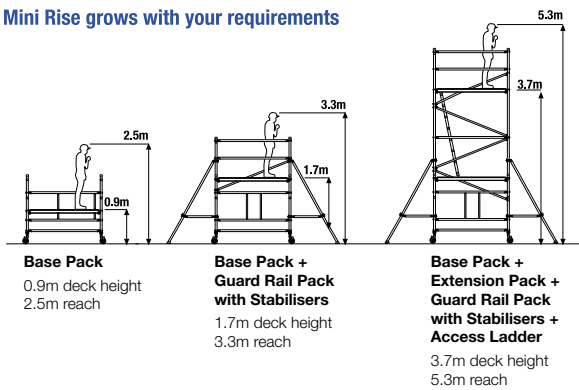

| Product No. | Description | EAN Code | Weight |
|-------------|----------------------------------|---------------|--------|
| FS10631 | Base Pack | 9312097014848 | 34.0kg |
| FS10632 | Extension Pack | 9312097014855 | 44.1kg |
| FS10666 | Guard Rail Pack with Stabilisers | 9312097015937 | 33.6kg |
| FS23045 | Adjustable Leg Pack | 9312097014886 | 5.0kg |
| FS10636 | Access Ladder | 9312097015494 | 4.9kg |



Rapid Rise™ – Aluminium 225kg W.L.L. (2 person)

Mobile Scaffolding

- Tested and Passes AS/NZS 1576.1 &.3
- 225kg W.L.L (2 person)
- Registered design by New South Wales Work Cover. REG# PFS 6-90281/06
- Extra wide and stable working platform (1300mm x 2500mm) up to a maximum platform height of 3.9m
- Access platform included to allow ladder access to the top deck
- Adjustable Screw Jacks included as standard for use on uneven or sloping surface
- Large 8" non-marking castor wheels
- Complete with full work instructions
- Fully welded construction
- Super tough T6 Aluminium frames and braces
- Quick set up and pull down time
- Weather resistant platforms made from marine grade ply board
- Lockable castors for easy and quick relocation
- Designed for industrial and trade applications
- Australian made and owned

Rapid Rise grows with your requirements

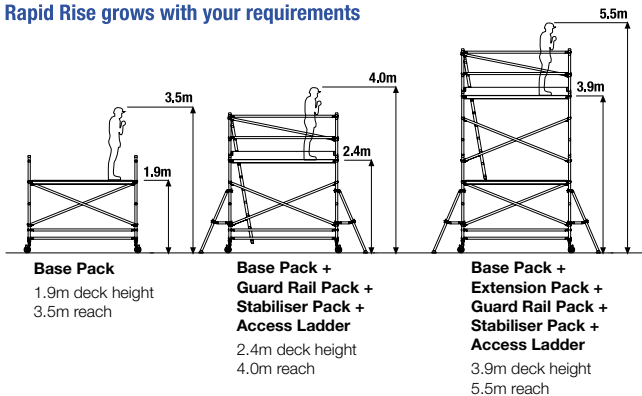

| Product No. | Description | EAN Code | Weight |
|-------------|-----------------|---------------|--------|
| FS10903 | Base Pack | 9312097027114 | 86.0kg |
| FS10905 | Extension Pack | 9312097027138 | 47.6kg |
| FS10904 | Guard Rail Pack | 9312097027121 | 34.3kg |
| FS10970 | Stabiliser Pack | 9312097027497 | 15.5kg |
| FS10971 | Access Ladder | 9312097027503 | 10.2kg |



Fibreglass 150kg Single Sided Stepladder (RFSS)

PROFESSIONAL INDUSTRIAL
150kg

- Punchlock® tread design and deep fascia top caps increase torsional rigidity of the overall ladder frames
- Industrial Duty Rated. Designed for use on industrial work sites where greater strength and safety is required
- Heavy Duty, 150kg Load Rating
- Strong, fibreglass construction with triangular plate bracing
- Electro-Safe™
- Internal spreader arms, heavy duty steel – cross braced. Available on models 1.8 to 3.6m
- Anti-slip rubber “Boots” for maximum grip on any surface and protection of the stiles
- Made to Australian and New Zealand Standards AS/NZS 1892.3
- Australian made and owned

| Product No. | Description | Size | Reach Height | EAN Code | Weight |
|-------------|-------------|------------|--------------|---------------|--------|
| FS10490 | RFSS 3 | 0.9m (3') | 2.3m | 9312097008168 | 4.5kg |
| FS10491 | RFSS 4 | 1.2m (4') | 2.6m | 9312097008175 | 5.5kg |
| FS10492 | RFSS 6 | 1.8m (6') | 3.2m | 9312097008182 | 8.8kg |
| FS10493 | RFSS 7 | 2.1m (7') | 3.5m | 9312097008199 | 9.8kg |
| FS10494 | RFSS 8 | 2.4m (8') | 3.8m | 9312097008205 | 11.6kg |
| FS10495 | RFSS 10 | 3.0m (10') | 4.4m | 9312097008212 | 17.1kg |
| FS10496 | RFSS 12 | 3.6m (12') | 5.0m | 9312097008229 | 20.9kg |



Fibreglass 150kg Double Sided Stepladder (RFDS)

PROFESSIONAL INDUSTRIAL
150kg

- Punchlock® tread design and deep fascia top caps increase torsional rigidity of the overall ladder frames
- Industrial Duty Rated. Designed for use on industrial work sites where greater strength and safety is required
- Heavy Duty, 150kg Load Rating
- Strong, fibreglass construction with triangular plate bracing
- Electro-Safe™
- Double sided for greater versatility and greater load bearing strength
- The incorporation of interlocking top caps also adds strength and stability
- Internal spreader arms, heavy duty steel – cross braced. Available on models 1.8 to 3.6m
- Anti-slip rubber “Boots” for maximum grip on any surface and protection of the stiles
- Made to Australian and New Zealand Standards AS/NZS 1892.3
- Australian made and owned

| Product No. | Description | Size | Reach Height | EAN Code | Weight |
|-------------|-------------|------------|--------------|---------------|--------|
| FS10483 | RFDS 3 | 0.9m (3') | 2.3m | 9312097007178 | 5.5kg |
| FS10484 | RFDS 4 | 1.2m (4') | 2.6m | 9312097007185 | 7.0kg |
| FS10485 | RFDS 6 | 1.8m (6') | 3.2m | 9312097007192 | 10.6kg |
| FS10486 | RFDS 7 | 2.1m (7') | 3.5m | 9312097008038 | 12.5kg |
| FS10487 | RFDS 8 | 2.4m (8') | 3.8m | 9312097008076 | 14.5kg |
| FS10488 | RFDS 10 | 3.0m (10') | 4.4m | 9312097008083 | 20.3kg |
| FS10489 | RFDS 12 | 3.6m (12') | 5.0m | 9312097008090 | 25.5kg |



Fibreglass 150kg Step Extension Ladder

PROFESSIONAL INDUSTRIAL
150KG

- Punchlock® tread design and deep fascia top caps increase torsional rigidity of the overall ladder frames
- Industrial Duty Rated. Designed for use on industrial work sites
- 150kg Load Rating
- Strong, fibreglass construction
- Electro-Safe™
- Highly versatile and easily converts from a stepladder to an extension ladder
- Rear leg extends in 300mm increments
- Strong and safe extended ladder position ensured by heavy duty locking hinges and a full step overlapping construction
- Anti-slip rubber “Boots” for added safety, stability and protection of the stiles
- ‘V’ rung as standard for pole work
- Made to Australian and New Zealand Standards AS/NZS 1892.3
- Australian made and owned

| Product No. | Description | Size | Reach Height | EAN Code | Weight |
|-------------|-------------|-------------------|--------------|---------------|--------|
| FS10444 | FSE 6 | 1.8/3.2m (6'/10') | 3.2/4.2m | 9312097006188 | 12.6kg |
| FS10445 | FSE 7 | 2.1/3.8m (7'/12') | 3.5/4.8m | 9312097006195 | 14.4kg |
| FS10446 | FSE 8 | 2.4/4.1m (8'/13') | 3.8/5.1m | 9312097006201 | 15.8kg |



Fibreglass 120kg Dual Purpose Stepladder

PROFESSIONAL INDUSTRIAL
120KG

- Punchlock® tread design and deep fascia top caps increase torsional rigidity of the overall ladder frames
- Industrial Duty Rated. Designed for use on industrial work sites
- 120kg Load Rating
- Strong, fibreglass construction
- Electro-Safe™
- Highly versatile and easily converts from a stepladder to a single ladder
- Strong and safe straight ladder position latched by heavy duty locking hooks and a full step overlapping construction
- Tapered back legs provide added stability when used as a stepladder
- Anti-slip rubber “Boots” for maximum grip on any surface and protection of the stiles
- Made to Australian and New Zealand Standards AS/NZS 1892.3
- Australian made and owned

| Product No. | Description | Size | Reach Height | EAN Code | Weight |
|-------------|-------------|-------------------|--------------|---------------|--------|
| FS10480 | RFDP 6 | 1.8/3.2m (6'/10') | 3.2/4.2m | 9312097007130 | 10.1kg |
| FS10481 | RFDP 7 | 2.1/3.8m (7'/12') | 3.5/4.8m | 9312097007147 | 11.8kg |
| FS10482 | RFDP 8 | 2.4/4.4m (8'/13') | 3.8/5.4m | 9312097007161 | 13.4kg |



Fibreglass 150kg Platform Stepladder

PROFESSIONAL INDUSTRIAL
150kg

with Safety Gate (Temporary Work Platform)

- Punchlock® tread design increases the torsional rigidity of the overall ladder frame
- Industrial Duty Rated. Designed for use on industrial work sites where greater strength and safety is required
- Heavy Duty, 150kg Load Rating
- Strong, fibreglass construction with triangular plate bracing
- Electro-Safe™
- Wide, anti-slip platform (490mm x 400mm) for a secure work area
- Multi function polypropylene handrail/accessories holder
- 900mm handrail height from platform
- Anti-slip rubber "Boots" for added safety, stability and protection of the stiles
- Made to Australian and New Zealand Standards AS/NZS 1892.3
- Available – optional retractable Castor/Wheel Kits – optional 'fold away' Safety gate
- Australian made and owned

| Product No. | Description | Platform Height | Reach Height | EAN Code | Weight |
|-------------|---------------------------|-----------------|--------------|---------------|---------|
| FS13339 | FG PFS 3 with Safety Gate | 0.9m (3') | 2.9m | 9312097053991 | 13.55kg |
| FS13340 | FG PFS 4 with Safety Gate | 1.2m (4') | 3.1m | 9312097054004 | 14.95kg |
| FS13341 | FG PFS 5 with Safety Gate | 1.5m (5') | 3.4m | 9312097054011 | 16.45kg |
| FS13342 | FG PFS 6 with Safety Gate | 1.8m (6') | 3.7m | 9312097054028 | 18.35kg |
| FS13343 | FG PFS 7 with Safety Gate | 2.1m (7') | 4.0m | 9312097054035 | 22.55kg |
| FS13344 | FG PFS 8 with Safety Gate | 2.4m (8') | 4.3m | 9312097054042 | 24.95kg |



Fibreglass 150kg Platform Stepladder

PROFESSIONAL INDUSTRIAL
150kg

without Safety Gate (Temporary Work Platform)

| Product No. | Description | Platform Height | Reach Height | EAN Code | Weight |
|-------------|-------------|-----------------|--------------|---------------|--------|
| FS10720 | FG PFS 2 | 0.6m (2') | 2.6m | 9312097021228 | 9.7kg |
| FS10721 | FG PFS 3 | 0.9m (3') | 2.9m | 9312097021235 | 11.0kg |
| FS10722 | FG PFS 4 | 1.2m (4') | 3.1m | 9312097021242 | 12.5kg |
| FS10723 | FG PFS 5 | 1.5m (5') | 3.4m | 9312097021259 | 14.0kg |
| FS10724 | FG PFS 6 | 1.8m (6') | 3.7m | 9312097021266 | 15.9kg |
| FS10725 | FG PFS 7 | 2.1m (7') | 4.0m | 9312097021273 | 20.1kg |
| FS10726 | FG PFS 8 | 2.4m (8') | 4.3m | 9312097021280 | 22.5kg |



Optional Castor/Wheel Kits

| Product No. | Description | EAN Code | Weight |
|-------------|-----------------------|---------------|--------|
| FS23120 | Castor/Wheel Kit 2-6' | 9312097050044 | 2.54kg |
| FS23121 | Castor/Wheel Kit 7-8' | 9312097050051 | 2.54kg |



Fibreglass 150kg Extension Ladder (FXN™)

PROFESSIONAL INDUSTRIAL
150KG

- Industrial Duty Rated. Designed for use on industrial work sites
- 150kg Load Rating on sizes 8', 10', 12' and 14'
- 140kg Load Rating on sizes 16' and 18'
- XHD fibreglass construction resists sway, turn and flex
- Electro-Safe™
- Complete with pole chain and hoop as standard
- Rungs top-hat riveted for resistance to twist and sway
- Convenient side pulley and rope extension system
- Rubber 'boots' for extra safety and protection of the fibreglass stiles
- Made to Australian and New Zealand Standards AS/NZS 1892.3
- A range of pole support devices can be fitted to this ladder to suit your needs, made to order or supplied as accessories
- Bailey Level-Eze® Ladder Leveller and accessories available
- Australian made and owned

| Product No. | Description | Size | Reach Height | EAN Code | Weight |
|-------------|-------------|----------------------|--------------|---------------|--------|
| FS20186 | FXN 8/14 | 2.70/3.9m (8'/13') | 3.70/4.9m | 9312097016088 | 18.9kg |
| FS20187 | FXN 10/17 | 3.31/5.13m (10'/17') | 4.31/6.13m | 9312097016095 | 24.2kg |
| FS20188 | FXN 12/21 | 3.92/6.35m (12'/21') | 4.92/7.35m | 9312097016101 | 26.9kg |
| FS20189 | FXN 14/25 | 4.50/7.57m (14'/25') | 5.50/8.57m | 9312097016118 | 31.0kg |
| FS20190 | FXN 16/29 | 5.14/8.79m (16'/29') | 6.14/9.79m | 9312097016125 | 33.5kg |
| FS20411 | FXN 18/31 | 5.72/9.38m (18'/31') | 6.72/10.38m | 9312097015425 | 36.2kg |



Fibreglass 130kg Extension Ladder (FSXN™) with V Bracket

PROFESSIONAL INDUSTRIAL
130KG

- Punchlock® flat 'D' shaped rungs for secure footing
- Industrial Duty Rated. Designed for use on industrial work sites
- 130kg Load Rating on sizes 8', 10', 12', 13' and 14'
- 125kg Load Rating on sizes 16'
- XHD fibreglass construction resists sway, turn and flex
- Electro-Safe™
- Fitted with pole support 'V' Bracket
- Patented convenient side pulley and rope extension system to keep rope away from the user's feet
- Rubber 'boots' with reinforcing plate for extra safety and protection of the fibreglass stiles
- Made to Australian and New Zealand Standards AS/NZS 1892.3
- Bailey Level-Eze® Ladder Leveller and accessories available
- Australian made and owned

| Product No. | Description | Size | Reach Height | EAN Code | Weight |
|-------------|-------------------------|----------------------|--------------|---------------|--------|
| FS20405 | FSXN 8/14 w/ V Bracket | 2.68/4.20m (8'/14') | 3.68/5.20m | 9312097015364 | 17.5kg |
| FS20406 | FSXN 10/17 w/ V Bracket | 3.29/5.42m (10'/17') | 4.29/6.42m | 9312097015371 | 20.4kg |
| FS20407 | FSXN 12/21 w/ V Bracket | 3.90/6.64m (12'/21') | 4.90/7.64m | 9312097015388 | 23.9kg |
| FS20408 | FSXN 13/23 w/ V Bracket | 4.20/6.95m (13'/23') | 5.20/7.95m | 9312097015395 | 25.2kg |
| FS20409 | FSXN 14/25 w/ V Bracket | 4.50/7.56m (14'/25') | 5.50/8.56m | 9312097015401 | 26.5kg |
| FS20410 | FSXN 16/29 w/ V Bracket | 5.12/8.78m (16'/29') | 6.12/9.78m | 9312097015418 | 30.0kg |



Fibreglass 130kg Extension Ladder (FSXN™)

PROFESSIONAL INDUSTRIAL
130kg

- Punchlock® flat 'D' shaped rungs for secure footing
- Industrial Duty Rated. Designed for use on industrial work sites
- 130kg Load Rating on sizes 8',10',12',13' and 14'
- 125kg Load Rating on sizes 16'
- Strong fibreglass construction
- Electro-Safe™
- Patented convenient side pulley and rope extension system to keep rope away from the users' feet
- Rubber 'boots' for extra safety and protection of the fibreglass stiles
- Made to Australian and New Zealand Standards AS/NZS 1892.3
- Bailey Level-Eze® Ladder Leveller and accessories available
- Australian made and owned

| Product No. | Description | Size | Reach Height | EAN Code | Weight |
|-------------|-------------|----------------------|--------------|---------------|--------|
| FS20324 | FSXN 8/14 | 2.68/4.20m (8'/14') | 3.68/5.20m | 9312097016316 | 16.1kg |
| FS20325 | FSXN 10/17 | 3.29/5.42m (10'/17') | 4.29/6.42m | 9312097016323 | 19.0kg |
| FS20326 | FSXN 12/21 | 3.90/6.64m (12'/21') | 4.90/7.64m | 9312097016330 | 22.5kg |
| FS20327 | FSXN 13/23 | 4.20/6.95m (13'/23') | 5.20/7.95m | 9312097016347 | 23.8kg |
| FS20328 | FSXN 14/25 | 4.50/7.56m (14'/25') | 5.50/8.56m | 9312097016354 | 25.1kg |
| FS20329 | FSXN 16/29 | 5.12/8.78m (16'/29') | 6.12/9.78m | 9312097016361 | 28.6kg |



Fibreglass 130kg Single Ladder (FSS™)

PROFESSIONAL INDUSTRIAL
130kg

- Punchlock® flat 'D' shaped rungs for surer footing and strength
- Industrial Duty Rated. Designed for use on industrial work sites
- 130kg Load Rating
- Strong, fibreglass construction
- Electro-Safe™
- Anti-slip rubber "Boots" for added safety, stability and protection of the stiles
- Made to Australian and New Zealand Standards AS/NZS 1892.3
- Bailey Level-Eze® Ladder Leveller and accessories available
- Australian made and owned

| Product No. | Description | Size | Reach Height | EAN Code | Weight |
|-------------|-------------|-------------|--------------|---------------|--------|
| FS20333 | FSS 8 | 2.57m (8') | 3.57m | 9312097015456 | 6.6kg |
| FS20334 | FSS 10 | 3.18m (10') | 4.18m | 9312097020252 | 8.3kg |
| FS20335 | FSS 12 | 3.79m (12') | 4.79m | 9312097020269 | 9.5kg |
| FS20336 | FSS 14 | 4.40m (14') | 5.4m | 9312097020276 | 11.7kg |
| FS20337 | FSS 16 | 5.01m (16') | 6.01m | 9312097015463 | 13.2kg |



For further information, please contact
our Customer Service Centre
1300 303 077
www.hills.com.au



Designed and tested under a
Quality System that meets Hills
demanding quality specifications.

This brochure has been printed
on FSC Certified Paper.

Hills Holdings Limited
A.B.N. 35 007 573 417

All details in this brochure are correct at time of printing. Hills reserves
the right to alter product specifications at any time without notice.

Brochure Code



BRO53

Sept 2011